

It often happens that a camera or a sensor needs to be moved precisely in a defined direction. A studio stand which moves on a rail is suitable for this purpose.

MUFUS: special cast base that moves smoothly on a floor rail. MUFUS is based on the ARBOF base and matches the studio stands ASABA, AROBI (DSS GAMMA) and together with the flange ASLEI the ASLAI (Portrait Pro).

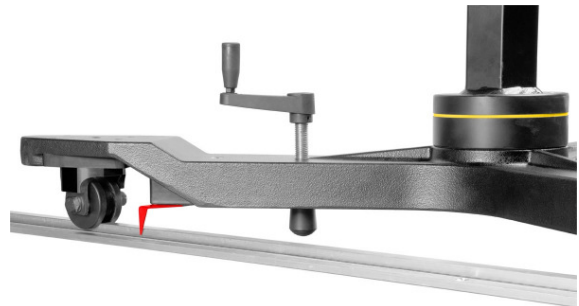

Properties of MUFUS

Like ARBOF, plus:

- Fixation of the base on the floor with a hand crank
- Red arrow for precise positioning

MURAI: Floor rail for MUFUS, up to 6 m long piece; can be lengthened with additional rails; with end stopper; screwed to the ground.

MUSCA: Millimetre scale which adheres to the MURAI floor rail, up to 3.6 m in length.

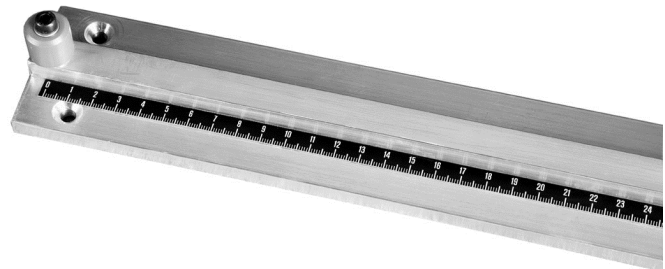

The two most common movement directions:

A: Movement parallel to the object to be photographed or scanned, e.g. in order to photograph large objects by taking pictures of many small sections or for the analysis of a painting with a microscope.

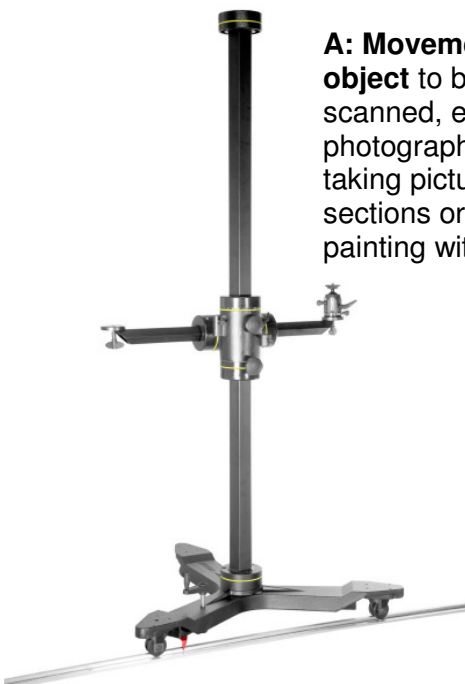

B: Movement perpendicular to the object to be photographed, e.g. for focussing on variously sized objects or for the calibration of lenses.

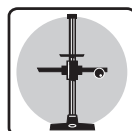

Subject to technical modifications

Made in Switzerland
Made by **FOBA**[®]