

Accessories for Digital Photography

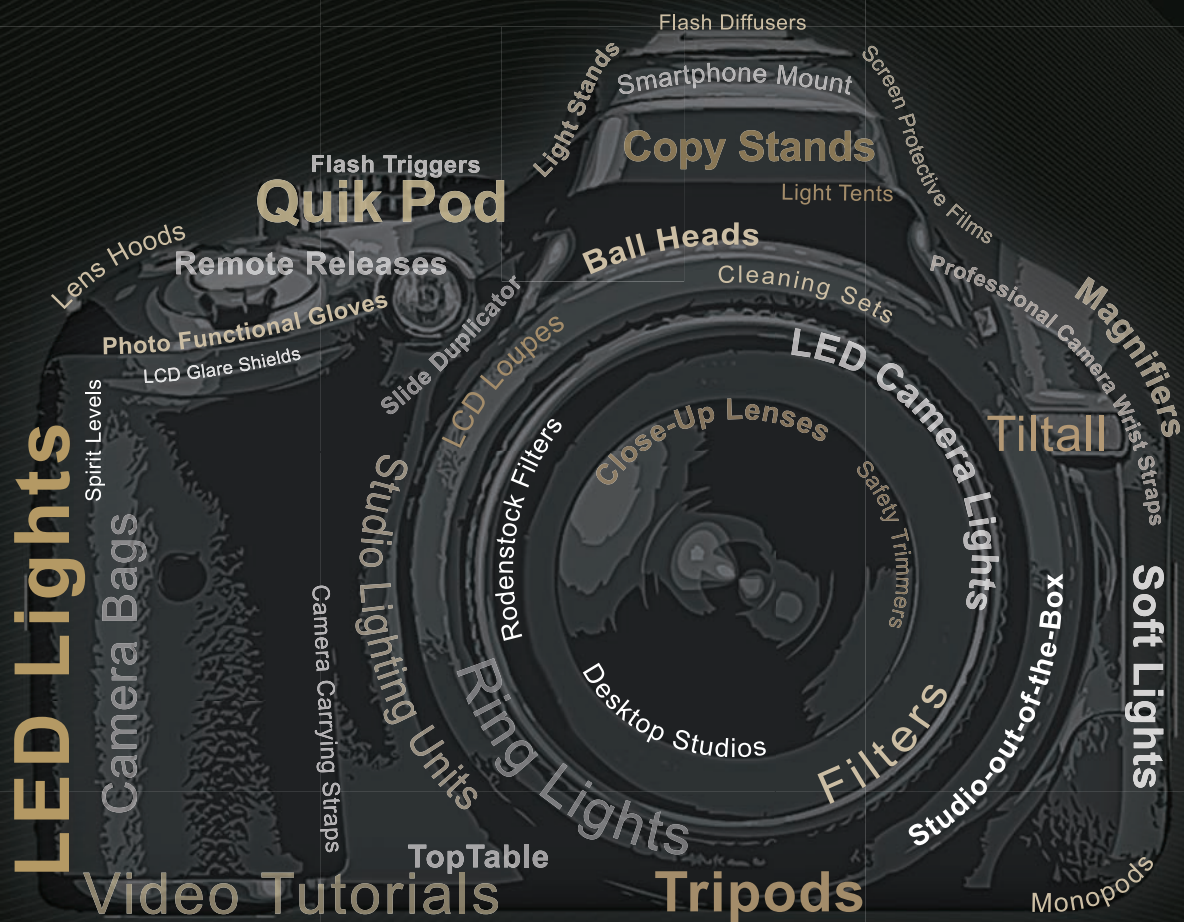

photokina
With New Products

It's More Than Three Legs:

Tiltall tripods are modern tripods with a history behind them, because since almost 70 years there are Tiltall tripods on the market. But this is another story, that cannot be told now. Here are the facts for today's Tiltall tripods and you will see: There is more to it than three legs!

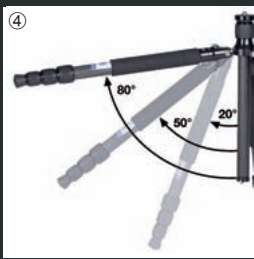
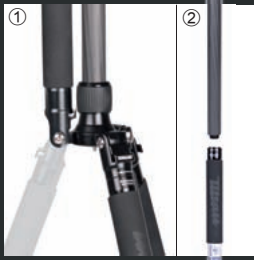

Tiltall Tripods

- Sturdy tripods. Tripod legs and column made from eight-layer carbon with little weight and very good vibration absorption (6069-6071) resp. aircraft aluminium (6066-6068).
- 180 degrees reversible legs for reduced pack size. ❶
- One tripod leg is detachable and can be converted to a monopod by adding the removable center column. ❷
- Reversible center column for macro shots. Center column can also be removed for close-to-ground level-setting. ❸
- Four-section tripod legs with anti-twist protection and twist locks for fast and easy operation.
- Spread angle of legs can be individually adjusted and locked in three positions, covered ratchet tothing with release button. ❹
- Extendable center column with anti-twist device, twist lock and spring loaded hook.
- Rubber feet with retractable metal spikes made from stainless steel.
- 1/4"-3/8" interchangeable thread.
- Tripod legs with leg warmers made of foam layers.
- Padded carrying case with adjustable shoulder strap and carry handle. ❺

Code no.	6066	6067	6068
Type	TE-224	TE-254	TE-284
Material	Alu	Alu	Alu
Tube ø, max. (mm)	22	25.5	29
Max. height (cm)	140	147	162
Min. height (cm)	14	14	15
Pack size (cm)	40	43	47
Monopod height	68-145	71-152	78-169
Weight (kg)	1.1	1.4	1.8
Max. load (kg)	8	8	12
Recommended ball head	BH-10	BH-20	BH-30

Code no.	6069	6070	6071
Type	TC-224	TC-254	TC-284
Material	Carbon	Carbon	Carbon
Tube ø, max. (mm)	22	25.5	29
Max. height (cm)	140	147	162
Min. height (cm)	14	14	15
Pack size (cm)	40	43	47
Monopod height	68-145	71-152	78-169
Weight (kg)	0.9	1.1	1.4
Max. load (kg)	8	8	12
Recommended ball head	BH-10	BH-20	BH-30



NEW Tiltall Travel Tripods „2go“

Light-weight tripods with especially compact pack size!

- Optionally carbon or aluminium
- Five-section tripod legs with anti-twist protection. Spread angle of legs can be individually adjusted and locked in three positions, covered ratchet tothing. 180 degrees reversible legs. Anti-skid rubber feet. One leg with leg warmer.
- Movable and extendable center column, with twist locks and load hook. Reversible center column for macro shots. Tripod can also be used without center column. 1/4" / 3/8" interchangeable thread.
- One detachable tripod leg can be used as a monopod.
- Padded carrying case.

Code no.	6057	6058
Type	TE-225	TC-225
Material	Alu	Carbon
Tube ø, max. (mm)	22	22
Max. height (cm)	123	123
Min. height (cm)	12.5	12.5
Pack size (cm)	31.5	31.5
Monopod height	49-125	49-125
Weight (kg)	0.95	0.8
Max. load (kg)	7	7
Recommended ball head	BH-07	BH-07

1:1
Original size



Tiltall

NEW Tiltall Bi-Pod

- Compact and sturdy monopod (carbon) with tripod base (alu) for safe standing.
- Can be used as a conventional monopod when tripod base is detached (for description and specs see MP-284C monopod (code no. 6061).
- 180 degrees reversible tripod base legs for reduced pack size.
- Spread angle of legs can be individually adjusted and locked in three positions, covered ratchet toothing with automatic reset release button.
- Tripod base legs with non-slip rubber feet.
- Comes with a padded carrying case with adjustable shoulder strap with adjustable shoulder strap and carry handle.

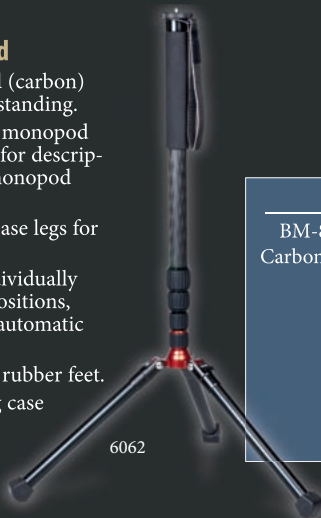

6062	Code no.	6060	6061	6063	6064
BM-868C	Type	MP-284	MP-284C	MP-315	MP-315C
Carbon/Alu	Material	Alu	Carbon	Alu	Carbon
4	Sections	4	4	5	5
29	Tube ø, max. (mm)	29	29	32.5	32.5
189	Max. height (cm)	162	162	187	187
59	Min. height (cm)	51	51	50	50
54	Pack size (cm)	51	51	50	50
860	Weight (g)	550	420	650	490
8	Max. load (kg)	11	12	14	15



Code no.	6009	6001	6002	6003
Type	BH-07	BH-10	BH-20	BH-30
Ball diameter (mm)	30	30	36	44
Height (mm)	87	92	98	107
Socket-ø (mm)	45	45	51	60
Weight (g)	330	360	440	570
Max. load (kg)	8	8	10	12
Suitable for tripods	TE-225 TC-225	TE-224 TC-224	TE-254 TC-254	TE-284 TC-284

Tiltall Ball Heads

- Solid ball head with dovetail clamping (Arca-Swiss compatible).
- Quick-release plate with non-slip surface, detachable slide-off protection and 1/4" D-ring screw.
- Three spirit levels for exact alignment.
- Adjustable friction (except BH-07).
- 360 degree panning socket with blocking screw and graduated scale.
- 3/8" tripod bush.
- Quick-release plates are also available individually.



Tiltall Quick Release Plates

Quick release system with dovetail clamping and blocking screw (Arca-Swiss compatible). Detachable slide-off protection and 1/4" camera screw, width 39 mm, height 10 mm. Any quick release plate is suitable for all Tiltall ball heads (6001-03, 6009).

6007: Length 100 mm

6006: Length 60 mm

6005: Length 50 mm

6004: Length 40 mm



Action Level Sound
Digital spirit level. Can be used in portrait and landscape formats. Levelling is indicated by LEDs and/or varying beep sounds (can be switched off). Fits in standard hot shoe.



Duplex Screw-In Spirit Level
Mounts in between camera and tripod.

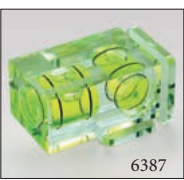

Duplex Spirit Level
With twin levels and mounting feet for landscape and portrait position.

Selfies in Action

Selfies – these self-portrait photographs taken with a digital camera or smartphone held at arm's length – are so cool today. But in many cases your arm is too short for a group selfie. Quik Pod will give your arm additional length. That's also quite convenient if you want to see more of the background on the picture or when shooting over the heads of a crowd blocking your view. As a matter of fact Quik Pod DSLR Action has an adapter for GoPro® action cams and is completely fit for outdoor use.

Quik Pod DSLR Action

Extendable hand-held tripod and monopod, suitable for using cameras, camcorders and smartphones at sports, action and outdoor activities. Also suitable for underwater use (complies with ASTM B117 / ISO 9227 saltwater standard). Tilt head with quick release adapter. Quick release plate with 1/4" connecting thread. A mirror surface below the tilt head is useful for frame control.

Includes adapter plate for GoPro® cameras, rubberized monopod end cap, water-resistant wrist strap, pocket clip, bumper attachment, snap hook, key ring, tightening tool and carrying bag.



6039



6048

Length: 47 to 135 cm / 18.5 to 53.1 in.
Weight: 295 g / 10.4 oz.
Max. load: 1.5 kg / 3.3 lbs.
(3.5 kg / 7.7 lbs. used as a monopod)

Length: 19.5 to 52 cm / 7.5 to 20.5 in.
Weight: 85 g / 3 oz.
Load capacity: max. 450 g / 16 oz.

Includes snap-hook, protective cover, wrist strap and tripod feet.



Quik Pod basic

Slim extendable hand-held tripod made of aluminum with telescopic slide-out, ideal for fancy shots from unusual perspectives: from above, from below, around the corner or under water.

Small – But Going Strong

Table top tripods are extremely compact, but provide a firm support.



6016



6045



6045



6052



6016

6015



96008

DSLR Table Top Tripod

With three-section telescopic legs and extendable center column. 3-way pan head with tiltable camera platform. Height: 18-30 cm (7.1-11.8 in.), max load: 2 kg / (4.4 lbs.)

„Multi-Level“ Table Top Tripod

Height continuously adjustable, three-section telescopic feet, folds-down to compact size. Ball head with locking screw (6043) or with pan and tilt head (6052). **NEW**

Smartphone Mount

with two 1/4" tripod threads and rubberized quick clamp for universal applications. Clamp width 55-90 mm. **NEW**

Smartphone Stand (6016), comprising 6043 and 6015. **NEW**

„easy“ Camera Shoulder Pod

Combined shoulder pod and chest pod for cameras and camcorders. Pivoting mounting plate with 1/4" thread, securing pin and non-slip face. Length steplessly adjustable and lockable in any position. With adjustable strap.



TWIN1: Fully Released . . .

No matter if you want to use infrared, radio-controlled or wired release for your camera, you will find a suitable TWIN release. And as every release can be used wired or wireless, they are consequently called TWIN.

TWIN1 R3/R4: Infrared Wireless and Wired Remote Releases



Twin1 R4 Infrared Transmitter/Receiver Kit

Transmitter

- Applicable as an IR remote shutter release and cable release (for exceptions see survey below)
- Working range up to 100 m (330 ft.) with separate receiver, 50 m (165 ft.) (Nikon, Pentax, Samsung) or 25 m (82 ft.) (Canon) with cameras with built-in receiver
- Two-step release button, delay shot (wireless) and bulb shot mode
- Built-in flashlight LED
- Includes 1 m (39 in.) release cable

TWIN1 R4 Receiver (except for 6167). Streamlined design. Two red LEDs for release control. Size: 30 x 40 x 25 mm (1.2 x 1.6 x 1 in.).

TWIN1 R4N Receiver (6167). Extremely small and light-weight (6 g / 0.2 oz.). Red LED for release control. Powered by camera, needs no extra battery. Size: 15 x 15 x 22 mm (0.6 x 0.6 x 0.9 in.).



Twin1 R3

Transmitter only (similar to R4) for cameras which are already equipped with a built-in IR receiver. Release cable included. Working range up to 50 m (165 ft.) with Nikon, Pentax and Samsung cameras, up to 25 m (82 ft.) with Canon cameras.

TWIN1 RF: Radio-Controlled Wireless and Wired Remote Releases



Twin1 RF transmitter

- Applicable as an RC remote shutter release and cable release
- Working range up to 100 m (330 ft.)
- Two-step release button, delay shot (wireless) and bulb shot mode
- Built-in flashlight LED
- Operation frequency: 2.4 GHz
- Size: 88 x 26 x 17 mm, 19 g (3.5 x 1 x 0.7 in, 0.7 oz.)
- Includes 1 m (39 in.) release cable

Twin1 RF receiver (except for 6179)

- Streamlined design
- Two red LEDs for release control
- Size: 30 x 40 x 25 mm (1.2 x 1.6 x 1 in.)

Twin1 RFN receiver (6179)

- Extremely small and light-weight (6 g / 0.2 oz.)
- Red LED for release control
- Powered by camera, needs no extra battery
- Size: 15 x 15 x 22 mm (0.6 x 0.6 x 0.9 in.)



See page 6 for a product overview.

Even More



6131-34

TWIN1 ISR 2: The Multifunctional Cable Remote Release

- for interval exposure
- for timer-controlled exposure
- for long exposure
- for continuous shooting

Delayed start is supported. Timer and interval time ranges from 1 second to 99 hours, 59 minutes, 59 seconds. Exposure numbers range from 1 to 9.999. 4-way-operation button. All buttons can be locked to prevent unintentional operation. Beep sound can be switched off. Low battery warning. Normal shutter release can be used without a battery fitted, all other functions require a battery. Illuminated triple-spaced LCD. Easy user interface for all settings.

- Battery: 3V (CR 2032)
- Operating time: approx. 2 months
- Release cable length: approx. 1 m (39 in.)
- Size (w/o cable holder): 110 x 26 x 18 mm (4.3 x 1 x 0.7 in.)
- Weight: 26 g / 0.9 oz. (incl. batteries)

Product overview, see table below.

MonoCR: The Cable Release



6187-93

This compact and ergonomically shaped cable release is very similar to your camera's release button. Most useful in macro photography, when using large telephoto lenses or for long exposures, a cable release ensures vibration-free shooting.

Two-step release: At the first pressure point TTL metering and auto focus is activated, the second triggers the shutter. For bulb shots the button can be locked (color indicator). The release cable can be detached and extended using the 2 m (6.6 ft.) extension cable (code no. 6185).

- Length of coiled cord (extended): approx. 90 cm (35.4 in.)
- Dimensions: approx. 105 x 34 x 23 mm (4.1 x 1.3 x 0.9 in.)
- Weight: approx. 30 g (1.1 oz.)

Product overview, see table below.

Product Survey	Twin1 R3 System	Twin1 R4 System	Twin1 RF System	Twin1 ISR2 System	MonoCR System	MultiTrig System
Canon: 1D C, 1D X, 1D(s), 1D(s) Mark II(N)/III, 1D Mark IV, 5D (Mark II/Mark III), 6D, 7D, 10D, 20D, 30D, 40D, 50D, D30, D60		6169	6178	6131	6188	7001
Canon: 1000D, 1100D, 1200D, PowerShot G1X, G12, G15, G16; Fuji X-E1, X-E2, X-T1		6168	6177	6131	6187	7001
Samsung: NX 5, NX 10, NX 11, NX 100; Sigma: SD1 Merrill, SD14, SD15						
Canon: 60D, 70D, 100D, 300D, 350D, 400D, 450D, 500D, 550D, 600D, 650D, 700D; Pentax: *istD, *istDL(2), *istDS(2), K-3, K-5, K-5 II(S), K-7, K10D, K20D, K-30, K100D, K110D, K200D, 645D, 645Z; Samsung: GX-1L, GX-1S, GX-10, GX-20	6161	6168	6177	6131	6187	7001
Canon (IR only, no accessory terminal): EOS M, Pentax (IR only, no accessory terminal): K-m, K-r, K-x, X5	6161					
Nikon: D1, D1H, D1X, D2, D2H(s), D2X(s), D3(s), D3(x), D4, D4S, D200, D300(s), D700, D800(E), D810, ; Fuji: S3pro, S5pro		6167	6179	6133	6189	7001
Nikon: D90, D600, D3200, D3300, D5000, D5100, D5200, D5300, D7000, D7100, Coolpix P7700, P7800	6162			6133	6190	7001
Nikon (IR only, no accessory terminal): D40(x), D50, D60, D70(s), D80, D3000, 1 J1, 1 J2, 1 J3, 1 V1, 1 V2, 1 V3, Coolpix P7100	6162					
Nikon: D3100				6133	6190	7001
Sony: Alpha 33, 35, 37, 55, 57, 65, 77(II), 99, 100, 200, 300, 350, 450, 500, 550, 580, 700, 850, 900, Minolta: 5D, 7D		6170	6180	6134	6191	7001 plus 7008
Panasonic: FZ20, FZ30, FZ50, FZ100, FZ150, FZ200, FZ1000, G1, G2, G3, G5, G6, G10, GF1, GH1, GH2, GH3, GH4, GM1, GX1, GX7, L1, L10, LC1, Leica: Digilux 2, Digilux 3, V-Lux 1, V-Lux 2, V-Lux 3, V-Lux 4		6171	6181		6192	
Olympus: E-30, E-410, E-420, E-510, E-520, E-600, E-620, Pen E-P1, E-P2, E-P3, E-P5, E-PL2, E-PL3, E-PL5, E-PL6, E-PM1, E-PM2, OM-D E-M5, OM-D E-M10, SH-1, SP-100EE, SP-510UZ, SP-550UZ, SP-560UZ, SP-565UZ, SP-570UZ, SP-590UZ, SP-810UZ, SZ-11, SZ-20, SZ-30MR, XZ-1, XZ-2					6193	7001 plus 7010

to Release!



1 : 1
Original size

NEW

MultiTrig AS 5.1: Rather Triggy

MultiTrig is a combined camera and flash release in one unit. And if you think you have to tell it what to release, you can forget about it. It knows already and automatically chooses the respective function. Hey, that's triggy, isn't it? In addition the transmitter has an extra flash shoe, receiving all TTL information from the camera, provided it is mounted to your camera's flash shoe.

Now here are the details:

5 Functions in 1 Unit:

1. Wired shutter release
2. Wireless shutter release
3. Wireless studio or camera system flash release
4. Auto Sensing: Automatic switching over from shutter release to flash release
5. TTL Pass-Through: Transmitter has TTL signal pass through for Canon or Nikon TTL flashguns attached to transmitter and transmitter mounted on camera

- Up to 120 m working distance. 7 channels can be selected, indicated by LEDs.
- 2.4 GHz radio frequency.
- Sync speed up to 1/320 second.
- Shutter release cords for many (D)SLRs and mirrorless compacts from Canon, Fujifilm, Nikon, Pentax, Samsung and Sigma included (cords for Sony/Minolta and Olympus separately available).
- Batteries: transmitter 2 x AAA, receiver 2 x AAA (not included).



Product Survey

- 7001: MultiTrig AS 5.1 radio trigger set:
Transmitter, receiver, 2.5 mm to 3.5 mm flash sync cable, 3.5 mm to 6.35 mm plug adapter and 4 shutter release cords.
- 7002: MultiTrig AS 5.1R: additional receiver for MultiTrig AS 5.1 Radio Trigger Set, incl. 2.5 mm to 3.5 mm flash sync cable and 3.5 mm to 6.35 mm plug adapter.

Shutter Release Cords

- 7004: 1C Shutter Release Cord (already included in set code no. 7001) for Canon, Pentax, Samsung, Sigma and Fujifilm cameras with 2.5 mm remote port.
- 7005: 3C Shutter Release Cord (already included in set code no. 7001) for Canon cameras with N3 port.
- 7006: 1N Shutter Release Cord (already included in set code no. 7001) for Nikon and Fujifilm cameras with 10 pin port.
- 7007: 3N Shutter Release Cord (already included in set code no. 7001) for Nikon cameras from D90 to D7100.
- 7008: 1S Shutter Release Cord for Sony and Minolta cameras with 3 pin port.
- 7010: 3L Shutter Release Cord for Olympus PEN, OM-D, E-series (partially).

See page 6 for a product overview.



KAISER[®]
FOTOTECHNIK

More Triggery Flash Releases



TwinLink T2Di: The Combined Radio Frequency and Infrared Flash Trigger

Complete Kit with transmitter and receiver for wireless triggering of studio flash and camera flash systems. Combined triggering via 2.4 GHz radio frequency and infrared signals using eight high performance LEDs. 32 user selectable channels. Transmitter and receiver with LCD panels that can be illuminated and external aerials. Automatic power cut-down after pre-determined time and on/off switch. Transmitter can be attached using the camera's hot shoe or with an adhesive accessory shoe mount in a convenient location. Receiver with tripod thread and mounting magnets for attachment on metal surfaces or via an adhesive metal plate supplied with the set. Receiver has a hot shoe and trigger cable terminals for PC and 2.5 mm jack-plug. Battery or mains operation (mains adapter/charger code no. 6142 not included).

- Two simultaneous triggering signals for high operational reliability
- For studio and camera flash systems

- Max. working range: Indoor: approx. 50 m (150 ft.)
Outdoor: approx. 200 m (600 ft.)
- Max. sync speed: 1/250 sec. (depending on camera and flash)

Product Survey

6126: T2Di TwinLink set, consisting of transmitter and receiver, incl. PC cord, trigger cable 2.5-3.5, 3.5-6.3 adapter plug, adhesive accessory shoe base, 3 AAA batteries, 2 CR 2032 batteries, receiver fixture clip, adhesive metal plate.

6127: TwinLink T2RxDi receiver: incl. trigger cable 2.5-3.5, 3.5-6.3 adapter plug, adhesive metal plate, 3 AAA batteries, fixture clip.



FlashTrig 16 NEW The Radio Controlled Studio Flash Trigger



Compatible with many (D)SLRs and mirrorless CSCs. Transmitter with standard hot shoe mount and center contact and additional sync port socket. Low power consumption, long operating time. Flash test function. Battery operation.

Up to 30 m (100 ft.) working distance
16 channels can be selected
Sync speed up to 1/250 second
433 MHz radio frequency



Product Survey

7016: FlashTrig 16 radio trigger set:
Transmitter, receiver with 3.5 mm jack plug, 3.5 to 6.35 mm plug adapter, sync cable and 23A/12 V battery for transmitter. Receiver requires 2 AAA batteries (not included).

7017: FlashTrig 16R: additional receiver with 3.5 mm jack plug and 3.5 to 6.35 mm plug adapter. For triggering an additional studio flash in combination with FlashTrig 16 radio trigger set. Requires 2 AAA batteries (not included).



Flashy Accessories

„SoftCap“ Flash Diffuser **NEW**

Slide-on diffuser made from neutral-tint, translucent plastic. To avoid hard deep shadows and reflections and to get well-balanced illumination.

1531 for Canon Speedlite 320EX

1532 for Canon Speedlite 430EX/430EX II

1533 for Canon Speedlite 600EX-RT

1541 for Nikon Speedlight SB-400

1542 for Nikon Speedlight SB-700

1543 for Nikon Speedlight SB-900 / SB-910

1550 for Metz mecablightz 44 AF-1/52 AF-1

1551 for Metz mecablightz 48 AF-1/50 AF-1/58 AF-1/58 AF-2



Mounting Foot

6040

With accessory shoe for lighting units, flash guns etc. Tripod thread 1/4" for attachment on tripods. Dimensions: 94 x 63 x 11 mm (3.7 x 2.5 x 0.4 in.)



1304

Flash Adapter For flash units with standard ISO foot and center contact mounted on a Sony/Minolta DSLR camera with 4-pin foot.



1503

Remote Flash Trigger For wireless lag-free firing of a second flash unit. With standard ISO foot and hot flash contact.



1504

Remote Flash Trigger For wireless lag-free firing of a second flash unit. With 4-pin Sony/Minolta foot.



1000

Flash Bracket Light metal bracket with resilient contact surface. Length: 16.5 cm (6.5 in.).



1107

Angle Bracket Collapsible. Stable three-point rest.



1200

Bounce Flash Shoe For indirect flash illumination. Steplessly adjustable. Height: 45 mm (1.8 in.).



1300

Flash Shoe Adapter For cameras with hot flash shoe and flash equipment without hot flash shoe. With synchro flash socket.



1301

Flash Shoe Adapter For cameras without hot flash contact and flash equipment with hot flash contact. With synchro cable.



1303

Flash Adapter for connecting flash guns to receivers of RC remote releases, e.g. Kaiser MultiTrig/TwinLink, Pocket Wizard, etc.



1407

PC-PC Flash Cable With male PC plug at both ends to connect flashguns. Length: 5 m (16.4 ft.)



1405

PC-PC Spiral Cord With male PC plug at both ends to connect flashguns. Length: 65 cm (25.6 in.)



1322

Triple PC Flash Outlet For simultaneous use of up to three flash units with standard PC plugs.



1408/1409

Flash Cable With pull relief. 10 m (33 ft.). PC plug and jack plug ø 3.5 resp. 6.35 mm.



1420: 0,5 m
1423: 2 m

1424: 3 m
1425: 5 m
1426: 10 m

Extension Cord For connecting flash equipment. With right-angle plug and socket (PC).



1216

Mounting Shoe For mounting lights, flash units, etc. With 1/4" tripod thread.



1215

Accessory Shoe Adapter For cameras with Sony/Minolta flash shoe. Sony/Minolta ⇒ Standard/ISO

Vision Aids for Your Camera LCD



6074



6074



6075

„digiShield“ LCD Glare Shield

- digiShield shields lateral and angular incidence of light from the LCD monitor and improves the visibility of the monitor image.
- digiShield folds down completely and serves also as a cover and a screen protector.
- digiShield fits almost all digital compacts and is attached to the tripod socket.
- digiShield is available for 2.7" (digiShield²) and 3.0" LCDs (digiShield³) in silver and in black.
- digiShield has coil spring supported side flaps which open automatically.
- digiShield³ flips up completely to ease the operation of touch screen LCDs.

	6074	6054	6075	6055
Screen size (diag.):*	2,7" (6,9 cm)	2,7" (6,9 cm)	3,0" (7,6 cm)	3,0" (7,6 cm)
Designation:	digiShield ²	digiShield ²	digiShield ³	digiShield ³
Colour:	silver	black	silver	black

* eventually minor border covering with 6.9 cm (2.7")



6055

NEW SV 3.2 LCD Loupe

The SV 3.2 LCD loupe suits cameras with LCDs up to 3.2" (8.1 cm) and converts the LCD into a kind of electronic viewfinder especially useful when shooting videos. If annoying light incidence makes review of focus and composition difficult or even impossible, the SV 3.2 LCD loupe will produce immediate relief. It comes with 2x magnifying lens system made of optical glass with antireflection coating, a -5 to +3 dioptre adjustment, a soft eyecup and a solid plastic housing. It attaches to the camera by means of an elastic cord and can also be mounted to fold-out monitors. The cord serves also as a neck strap. The loupe is supplied with an artificial leather bag.



6083



SL3 LCD Loupe

The SL3 LCD loupe has been designed for DSLRs and CSCs with 3" LCD. It is not only a perfect shield against incident light, but enables, in any ambient light situation, an optimal examination of frame and focus while shooting and during playback. The built-in loupe has a double-side coated lens element with 2.3 magnification and diopter adjustment. Attaches to the camera via self-adhesive mounting frame where the hood clicks into place. Eyecup can be positioned for left or right eye viewing.



6084

Protective Shield: Screen Protectors for the Camera LCD

Anti-Reflective Screen Protective Film

VERGÜTET
Antireflex
HARD COATED

High-quality film for use with digital cameras. Protects the screen from scratches, dirt and fingerprints. **Glare-free by anti-reflective layer.** Has UV protection and hard coating, optimized for touch-screens. Attaches by adhesion due to silicone coating. Easy to apply, no bubbling. Can be removed without residues. 1 piece.

- 6085: for 6.4 cm (2.5") screens
- 6086: for 6.9 cm (2.7") screens
- 6088: for 7.1 cm (2.8") screens
- 6087: for 7.6 cm (3.0") screens
- 6090: for 8.9 cm (3.5") screens
- 6092: for 10.2 cm (4.0") screens
- 6095: for 7.6 cm (3.0") screens
- 6097: for 8.9 cm (3.5") screens



Also available custom-fit for these digital SLRs and CSCs:

- Canon EOS 1D C (6668)
- Canon EOS 1D X** (6668)
- Canon EOS 5D Mark III (6650)
- Canon EOS 6D (6667)
- Canon EOS 7D* (6616)
- Canon EOS 60D (6618)
- Canon EOS 70D (6676)
- Canon EOS 100D (6675)
- Canon EOS 600D (6618)
- Canon EOS 650D (6651)
- Canon EOS 700D (6676)
- Canon EOS 1100D (6619)
- Canon EOS 1200D (6681) **NEW**
- Canon EOS M (6664)
- Canon G1X Mark II (6675)
- Fujifilm HS 30 (6648) **NEW**
- Fujifilm X-A1, X-E2, X-M1 (6682) **NEW**

- Fujifilm X-T1 (6683) **NEW**
- Leica V-Lux 2 / V-Lux 3 (6632)
- Leica D-Lux 5 / D-Lux 6 (6631)
- Leica V-Lux 30/40 (6629)
- Nikon 1 V1 (6648)
- Nikon 1 V2, 1 J3 (6665)
- Nikon D4** (6669)
- Nikon D600/D610* (6643)
- Nikon D800/D810* (6649)
- Nikon D3200 (6644)
- Nikon D5100/D5200 (6646)
- Nikon D5300 (6680)
- Nikon D7000* (6645)
- Nikon D7100* (6670)
- Nikon P510 (6629)
- Olympus OM-D E-M1 / -M5 / -M10 (6642)
- Olympus PEN E-P3 / PEN E-P5 (6642)
- Panasonic G3/G5/GF3/GF5/GX1 (6628)
- Panasonic G6/GX7/GM1 (6677)
- Panasonic GF1/GF2 (6631)
- Panasonic GF6/GH3/GH4 (6642)
- Panasonic GH2/G2 (6632)
- Panasonic FZ45/LX 5/LX 7 (6631)
- Panasonic FZ48 (6628)
- Panasonic FZ100/FZ150/FZ200 (6632)
- Panasonic TZ18/22/25/31/36 (6629)
- Panasonic TZ41 (6618)
- Panasonic TZ56 (6677)
- Panasonic TZ61 (6631)
- Sony Alpha 7 / 7R / 7S (6641)
- Sony Alpha 33/35/55(6638)
- Sony Alpha 3000/5000/6000 (6638)
- Sony Alpha 57/65/77, HX 200 (6640)
- Sony NEX 3/C3/3N/5/5N/6/7/F3 (6638)

Layer composition

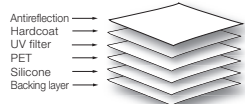

* additional film for status LCD included
** 2 films for status LCDs included



UV protection



Scratch resistant



Effective adhesion



No color tint



Touch optimised



Removable, no residues



Bubble-free application

„Crystal Clear“ Screen Protective Film

High-quality clear film for use with digital cameras. Protects the screen from scratches, dirt and fingerprints. **High level of transparency, hardly visible.** Has UV protection and hard coating, optimized for touch-screens. Attaches by adhesion due to silicone coating. Easy to apply, no bubbling. Can be removed without residues.

1 piece.

- 6079: for 6.9 cm (2.7") screens
- 6080: for 7.6 cm (3.0") screens
- 6081: for 8.9 cm (3.5") screens
- 6082: for 10.2 cm (4.0") screens
- 6093: for 7.6 cm (3.0") screens
- 6094: for 8.9 cm (3.5") screens



Layer composition

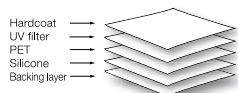

„Standard“ LCD Protective Film

For use with digital cameras, mobile phones and PDA's (6076 also for GPS). Protects the screen from scratches, dirt and fingerprints. Also for touch-screens. Can be removed without residues.

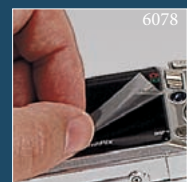

6076: Set with three 4 x 3" (10 x 8 cm) sheets each, with cutting lines for required size. Comes with cleaning cloths and a squeegee card to apply the film.

6078: For 3" LCD screens. Can be cut to fit smaller screens. Rounded corners. 3 pieces.



Lens Hoods

Designed for the lenses of digital SLRs. Fits onto the matching lens facing either forward for normal use or rearwards for storage (except 6887, mounts onto filter thread). Made of impact resistant plastic.



You Must Have This!

For lens	Code no.	Type
Canon EF-S 10-22/3.5-4.5 USM	6891	CW83E
Canon EF-S 15-85/3.5-5.6 IS USM	6879	CW78E
Canon EF 16-35/2.8L USM	6891	CW83E
Canon EF 16-35/2.8L II USM	6878	CW88
Canon EF 17-40/4.0L USM	6891	CW83E
Canon EF-S 17-55/2.8 IS USM	6892	CW83J
Canon EF-S 17-85/4.0-5.6 IS USM	6889	CW73B
Canon EF-S 18-55/3.5-5.6 IS STM	6864	CW63C NEW
Canon EF-S 18-55/3.5-5.6 IS (USM/II)	6880	CW60C
Canon EF-S 18-135/3.5-5.6 IS (STM)	6889	CW73B
Canon EF-S 18-200/3.5-5.6 IS	6890	CW78D
Canon EF 22-55/4.0-5.6	6880	CW60C
Canon EF 24-70/2.8L USM	6874	CW83F
Canon EF 24-70/2.8L II USM	6865	CW88C
Canon EF 24-85/3.5-4.5 (USM)	6881	CW73II
Canon EF 24-105/4.0L IS USM	6876	CW83H
Canon EF 28-80 (II/USM)	6880	CW60C
Canon EF 28-90/4-5.6 II (USM)	6880	CW60C
Canon EF 28-200/3.5-5.6 (USM)	6890	CW78D
Canon EF 28-300/3.5-5.6L IS USM, white	6875	CW83G
Canon EF 50/1.4 USM	6883	CS71II
Canon EF 50/1.8 II	6887	CS62
Canon EF-S 55-250/4.0-5.6 IS STM	6863	CT63 NEW
Canon EF-S 55-250/4.0-5.6 IS (II)	6888	CT60III
Canon EF-S 60/2.8 Macro USM	6886	CT67B
Canon EF 70-200/2.8L IS II USM, white	6873	CT87
Canon EF 70-200/4.0L (IS) USM, white	6870	CT74
Canon EF 70-210/3.5-4.5 USM,	6884	CT65III
Canon EF 70-300/4.0-5.6 IS USM	6885	CT65B
Canon EF 70-300/4.0-5.6L IS USM, white	6869	CT73B
Canon EF 75-300/4.0-5.6 III (USM)	6888	CT60III
Canon EF 70-300/4.5-5.6 DO IS USM	6885	CT65B
Canon EF 85/1.8 (USM)	6884	CT65III
Canon EF 90-300/4.5-5.6 (USM)	6888	CT60III
Canon EF 100/2.0 USM	6884	CT65III
Canon EF 100/2.8 USM/Makro USM	6866	CT67
Canon EF 100/2.8L Makro IS USM	6868	CT73
Canon EF 100-300/4.5-5.6 (USM)	6884	CT65III
Canon EF 100-400/4.5-5.6L IS USM, white	6871	CT83C
Canon EF 135/2.8 Soft-Fokus	6884	CT65III
Nikon AF-S DX 18-55/3.5-5.6G ED/EDII/VR	6894	NB45
Nikon AF-S DX 18-55/3.5-5.6G VR II	6897	NB69 NEW
Nikon AF-S DX 18-70/3.5-4.5G IF-ED	6893	NB32
Nikon AF-S DX 18-105/3.5-5.6G ED VR	6893	NB32
Nikon AF-S DX 55-200/4-5.6G ED VR	6895	NB37
Nikon AF-S DX 55-300/4.5-5.6G ED VR	6896	NB57 NEW
Nikon AF-S 18-135/3.5-5.6 IF-ED	6893	NB32
Sony DT 18-55/3.5-5.6 SAM (II)	6899	SH108

Lens Hoods for Pancake Lenses



Made of matte black rubber. Rotating connecting ring with metal mount and locking screw. Includes lens cap for use with mounted lens hood.

6829: For Panasonic Lumix G with 1.7/20 mm or 2.5/14 mm Pancake lens, also for JVC and Panasonic camcorders with 46 mm filter thread.

6831: For Olympus Pen with M.Zuiko Digital 2.8/17 mm Pancake lens, M.Zuiko Digital 3.5-5.6/14-42 mm II, Panasonic Lumix G X Vario PZ 3.5-5.6/14-42 mm, also for Canon, JVC and Sony camcorders with 37 mm filter thread.

3-in-1 Lens Hoods

for lenses with 28 to 200 mm focal length (35 mm equivalent). Made of matte black rubber, foldable. With light baffles. Metal screw-in mount. Filter thread.

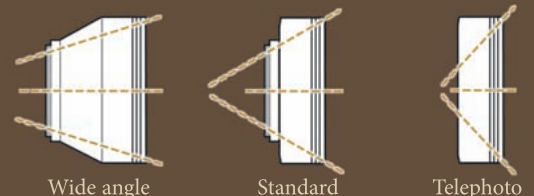

Wide angle	Standard	Telephoto
6850: ø 37 mm	6821: ø 52 mm	6825: ø 67 mm
6851: ø 43 mm	6822: ø 55 mm	6826: ø 72 mm
6853: ø 46 mm	6823: ø 58 mm	6827: ø 77 mm
6820: ø 49 mm	6824: ø 62 mm	

Even More for Your Lens: Filters

KAISER

The Kaiser filters and close-up lenses are equipped with a light alloy mount with front thread.



Kaiser UV Filters (101..)

Colourless filter. Blocks UV rays, so reduces haze, avoids blurring and improves contrast. Can be used as a permanent lens protector. Slim line metal mount, blackened at the lens edge to prevent glare effects. Double-sided coating. Supplied with storage box.

Kaiser UV Filters MC (102..)

Same as Kaiser UV filters (101..) but with six-layer multi-coating on both sides and water repellent lotus effect.

Kaiser Vario Grey Filter ND2x – ND400x

Neutral colour filter for variably reducing high brightness, extending exposure time and intentionally reducing the depth of field. Exposure factor 2 to 400.

Rotating the front ring reduces incidental light by 2 to 8 aperture increments. No vignetting with lenses of approx. 28 mm focal length and higher referred to full-frame. Comes with a lens cap, micro fibre cleaning cloth and pouch.



Close-Up Lens Set

Comprises Close-Up Lens 1 (+1 diopter), Close-Up Lens 2 (+2 diopters) and Close-Up Lens 4 (+4 diopters). Incl. case. To reduce the shooting distance and enlarge the frame. A combination of several close-up lenses is possible.



	ø 37	ø 40.5	ø 43	ø 46	ø 49	ø 52	ø 55	ø 58	ø 62	ø 67	ø 72	ø 77	ø 82
UV Filters (101..)	•	•	•	•	•	•	•	•	•	•	•	•	•
UV Filters MC (102..)	•	•	•	•	•	•	•	•	•	•	•	•	•
NEW Vario Grey Filters ND 2x - 400x (154..)	•	-	-	-	-	-	-	-	-	-	-	-	-
NEW Close-Up Lens Sets (145..)	-	-	-	-	-	•	•	•	•	•	•	•	-

R RODENSTOCK

Rodenstock „HR Digital super MC“ and „Digital pro MC“ Filters

Both these Rodenstock filter series are made from tempered glass with highest possible surface quality and are also highly scratch-resistant. Their flat slimline mounts prevent vignetting with wide-angle lenses. The front thread allows the use of a lens hood or of the lens cap with the filter in place. The filter mount of the less expensive Digital pro MC series is made from tempered, black anodized aluminum and is quite lightweight. The filter mount of the HR Digital super MC series is made from robust brass for optimum smooth movement of both threads. An additional water and oil repellent coating provide for the so-called lotus effect.

Rodenstock UV Filters

Steep Rodenstock UV blocking filters block out the UV radiation exactly at the border to visible light. This is extremely efficient and they are perfectly color neutral. Due to the perfect color neutrality Rodenstock UV blocking filters are also ideal protective filters that can be left on the lens at all times.



Rodenstock Circular Polarizing Filters

Circular Polarizers reduce or eliminate reflections on surfaces, reduce the diffuse blue cast in landscape photographs and produce an improved color saturation.

Rodenstock Neutral Density Filters ND 2x, 4x, 8x

They allow the extension of exposure times by a factor of 2, 4 or 8 for impressive smear effects or a

further opening of the aperture for a considerably reduced depth of field.

Rodenstock Variable Neutral Density Filters

If more than the fixed 2x, 4x and 8x ND levels or a finer graduation is required, the Digital Vario MC variable neutral density filter is the right solution.

	ø 34	ø 37	ø 39	ø 40.5	ø 43	ø 46	ø 49	ø 52	ø 55	ø 58	ø 62	ø 67	ø 72	ø 77	ø 82	ø 86	ø 95
„Digital pro UV MC“ UV Filters	•	•	-	•	•	•	•	•	•	•	•	•	•	•	•	-	-
„HR Digital UV super MC“ UV Filters	-	•	•	•	•	•	•	•	•	•	•	•	•	•	•	•	•
„Digital pro CPL MC, circ.“ Polarizing Filters	-	-	-	-	-	-	•	•	•	•	•	•	•	•	•	-	-
„HR Digital CPL super MC, circ.“ Polarizing Fil.	-	-	-	-	-	-	•	•	•	•	•	•	•	•	•	•	•
„HR Digital ND 0.3/2x MC“ Grey Filters	-	-	-	-	-	-	•	•	•	•	•	•	•	•	•	-	-
„HR Digital ND 0.6/4x MC“ Grey Filters	-	-	-	-	-	-	•	•	•	•	•	•	•	•	•	-	-
„HR Digital ND 0.9/8x MC“ Grey Filters	-	-	-	-	-	-	•	•	•	•	•	•	•	•	•	-	-
„Digital Vario ND 2 - ND 400 MC“ Grey Filters	-	-	-	-	-	-	•	•	•	•	•	•	•	•	•	-	-

You Should Have This!



ProDisk



Combination of white balance, grey card and colour reference in a slim, foldable plastic housing. Colour card and grey card located in lower and upper covers. Translucent white balance filter with special surface pattern in centre. Includes neck strap.

6601: ProDisk mini
for lenses up to \varnothing 6 cm (2.4 in.).
Dimensions (folded down):
103 x 73 x 10 mm (4.1 x 2.9 x 0.4 in.),
weight: 75 g (2.6 oz.)

6602: ProDisk II
for lenses up to \varnothing 9 cm (3.5 in.).
Dimensions (folded down):
145 x 101 x 11 mm (5.7 x 4.0 x 0.4 in.),
weight: 135 g (4.8 oz.)

„Vivicap“ White Balance Filter



Snap-on filter with specially designed prism structured surface for white-balancing of digital cameras and camcorders. Easy to use clamping mechanism provides for quick installation and removal. Serves also as a lens cap and can also be attached when a lens hood is used.

6605: \varnothing 52 mm 6608: \varnothing 62 mm 6610: \varnothing 72 mm
6606: \varnothing 55 mm 6609: \varnothing 67 mm 6611: \varnothing 77 mm
6607: \varnothing 58 mm

„Snap-On“ Lens Caps



Reliable hold by clamp-on design. Includes loss protection. Can also be used with lenshood mounted.

6845: \varnothing 37 mm 6835: \varnothing 55 mm 6840: \varnothing 77 mm
6847: \varnothing 43 mm 6836: \varnothing 58 mm 6841: \varnothing 82 mm
6848: \varnothing 46 mm 6837: \varnothing 62 mm 6842: \varnothing 86 mm
6833: \varnothing 49 mm 6838: \varnothing 67 mm
6834: \varnothing 52 mm 6839: \varnothing 72 mm

„slimlite LED“ Light Box



A compact and handy, super-flat daylight light box, to trans-illuminate transparent originals or as a backlight source for the „Digital“ slide duplicator (6506). Uniform illumination as a result of special light conducting and reflecting technology in conjunction with LEDs. Color temperature approx. 5000 K. ON/OFF switch. Protective cover included.

2447: Viewing area: approx. 10 x 12.5 cm (4 x 5 in.).
Dimensions (WxHxD): approx. 16 x 1.4 x 15 cm (6.3 x 0.6 x 5.9 in.). Power consumption: 1.2 W. Weight: approx. 260 g (9.2 oz.).
Battery or mains operation.*

2448: Viewing area: approx. 18 x 13 cm (7 x 5 in.).
Dimensions (WxHxD): approx. 22 x 2.1 x 19 cm (8.7 x 0.8 x 7.5 in.). Power consumption: 2 W.
Weight: approx. 550 g (1 lbs. 2 oz.).
Battery or mains operation.*

2449: Viewing area: approx. 30.5 x 20 cm (12 x 8 in.).
Light box with fold-out feet and clamping strip. Can be wall-mounted. Dimensions (WxHxD): approx. 37 x 2.5 x 27.5 cm (14.6 x 1 x 10.8 in.).
Power consumption: 6 W. Weight: approx. 1.300 g (2 lbs. 14 oz.). Mains adapter included.

* with additional mains adapter 2446 (accessory)

„Digital“ Slide Duplicator

Suitable for digital cameras with filter thread. Connecting thread 52 mm. With detachable achromatic macro lens. Full size copy can be obtained using it with a lens with focal length of 80-120 mm, details with higher focal length. Includes holder for two slides and 58-52 mm adapter ring.



6506

Film Strip Carrier
For six 35mm negatives or unmounted slides. For use with slide duplicator 6506.

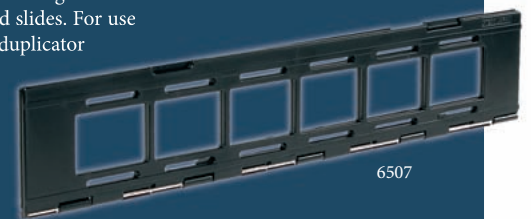

6507

Camera Body Caps



6521: for Canon EOS
6522: for Minolta MD
6523: for Sony/Minolta AF
6525: for Nikon
6526: for Olympus OM
6527: for Pentax K bayonet
6528: for Micro Four Thirds

Lens Rear Caps



6531: for Canon EOS
6532: for Minolta MD
6533: for Sony/Minolta AF
6535: for Nikon
6536: for Olympus OM
6537: for Pentax K bayonet
6538: for Micro Four Thirds

Keep It Clean



702002

Kinetronics' SpeckGRABBER Pro SGP (702002) removes individual particles of dust and dirt from sensitive surfaces without damaging them. Suitable for cleaning camera sensors (manufacturers instructions must be followed), SLR mirrors, lenses and oculars, films, slides, etc. With rubber-coated handle.



702004

SpeckGRABBER Pro Kit SGL

With integrated mini lamp, three tips, cleaning solution and anti-static cloth in robust box.



702005

SpeckGRABBER Pro Kit SGK

With SpeckGRABBER Pro handle, three tips, cleaning solution and anti-static cloth in robust box.



702001

SpeckGRABBER SG

With standard handle.



700001

Anti-Static Micro-Fibre Cloth

Specially conductive fibres, 700001 for dry cleaning, 706518 for wet cleaning.



700030

Anti-Static-Brushes

For sensitive surfaces. 700010: width 10 mm
700020: width 20 mm
700030: width 30 mm



707025

„ECK“ Optical Cleaning Set

With anti-static cloth 13 x 14.5 cm (5.1 x 5.7 in.) and 6 ml (0.2 oz.) of cleaning solution in a drop bottle.



707001

Outdoor Photographer's Optical Cleaning Kit

Cleaning solution, anti-static cloth and brush, SpeckGRABBER SG, Swabs.

„Typhoon Blower“ Blower Bellows

Large rubber bulb for strong blowing effect. Rugged front air nozzle, rear air duct valve. Easy to handle. Cleaning brush included.



6316

„Mini“ Blower Bellows

Compact rubber bulb. Fine, short front air nozzle, rear air duct valve. Easy to handle.



6305



6301

Lens Brush

In plastic tube. Lipstick twist mechanism.



6308

6309

6310

„Clear Gear“ Compressed Air

For touch-free dust removal.



6314

Blower Brush

Flat brush with large rubber blower bulb.



6328

Micro Fibre Cleaning Cloth

Fluff-free, grease-absorbing. Hemmed edges.



6662

Display and Optics Cleaning Kit

Pump spray and a micro fibre cleaning cloth.



6699

Cleaning Set

Lens cleaning paper, cleaning leather and blower brush.



6663

Cleaning Set

Cleaning pen and micro fibre cloth.



6697

Cleaning Set

Optical-glass cleaning fluid, cleaning paper and blower brush.

Portable Protection

„EasyLoader“ Camera Bags

With accessory pockets inside the outer lid and on both sides. Internal lid can be connected via a Velcro closure. Spacious front pocket with organizer pouches and zipper. This camera bag allows quick access, as the top opens away from the body and stays open in a fixed position. With carrying handle and detachable, adjustable and padded shoulder strap.

EasyLoader S (8817), inside dimensions: 13 x 12 x 9.3 cm
(5.1 x 4.7 x 3.7 in.) **NEW**

EasyLoader (8818), inside dimensions: 15.5 x 15 x 10.5 cm
(6.1 x 5.9 x 4.1 in.)



8818



8827

„SmartLoader“ Camera Bags

Lid opens away from the body and stays open in a fixed position thus providing quick access to the camera. Three mesh pockets. Zipped front pocket with overlapping cover and inside card pocket. Main compartment with divider. Padded handle. Adjustable carrying strap and shoulder pad. Belt loops.

SmartLoader S (8825), for megazoom cameras and camcorders.

Inside dimensions (WxHxD): 10.6 x 13 x 8.7 cm (4.2 x 5.1 x 3.4 in.).

SmartLoader M (8826), for bridge cameras, mirrorless interchangeable-lens cameras and camcorders. Inside dimensions (WxHxD): 16 x 10 x 9 cm (6.3 x 3.9 x 3.5 in.).

SmartLoader L (8827), for DSLR cameras. With lens support divider.

Inside dimensions (WxHxD): 17.5 x 13 x 10 cm (6.9 x 5.1 x 3.9 in.).

Battery Box

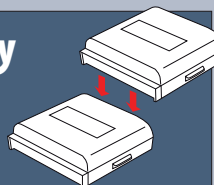

For 4 AA or AAA batteries.
2 pieces. Stackable.
Color: grey and blue



6497

Memory Card Box

Slim plastic box for secure storage of two SD or CompactFlash memory cards. Shaped rubber insert. Protects against shock, dirt and moisture. With secure latch.

6495:
grey

6496:
neon
yellow



„digiShell“ Hard Shell Camera Bags

Compact camera bags with hard shell exterior and two-way zipper. Interior accessory pocket. With belt loop, detachable carrying strap and snap hook.

digiShell 1,

9.5 x 6 x 2.5 cm
(3.7 x 2.4 x 1 in.)*

8281: black

8283: grey

*inside dimensions (WxHxD)

digiShell 2,

11 x 6.5 x 3.4 cm
(4.3 x 2.6 x 1.3 in.)*

8287: black

8289: grey



6494

Memory Card Box

Flat metal box for three SD/ Multimedia / xD / Memory Stick cards. Dimensions: approx. 9.5 x 6 x 0.5 cm (3.7 x 2.4 x 0.2 in.)



Keep a Firm Grip!

NEW „Action Strap“ Fast Access Strap

„Action Strap“ allows for safe carrying of your camera, but also for fast and easy access for shooting. The strap runs diagonally across breast and back, the camera rests sidewise on the hip. Via a short coupling piece the camera is connected to a threefold secured locking element that moves along the strap. The camera can be placed at any desired position by stops sliding along the strap, e.g. on your back when riding a bike, on your hip during a photo tour or on your chest when skiing. The coupling piece is attached to the tripod thread of the camera without the needs of any tools and rotates freely. Both ends of the strap are connected at shoulder height by means of a quick release lock with a 120° joint. The extra-wide shoulder pad is made from 8 mm soft Neoprene with a non-slip layer. A secondary adjustable strap fits under the arm to keep the main strap in position, especially during fast moves. The total length of the strap can be adjusted between 120 and 160 cm (47 and 63 inches).

Code no. 6760



Professional Camera Wrist Straps



6701



6702



6703

Suitable for larger compacts, (D)SLRs and CSCs. Soft padded genuine leather hand support with adjustable fixtures. 1 cm flat camera mounting plate with 1/4" tripod thread, counter-sunk fastening screw and nonslip camera support. Mounting plate of 6701 and 6702 with foldable legs providing a secure stand when put on table or floor. 6703 with Arca-Swiss compatible quick release plate. 6702 and 6703 with additional safeguard wrist strap.

6701: „Pro“ Wrist Strap

6702: „Pro 2.0“ Wrist Strap

6703: „Pro connexion“ Wrist Strap

NEW

Photo Functional Gloves



Half finger gloves with mitten cover and thumb cover provide for perfect mobility, secure grip and ideal protection against cold. Mitten and thumb cover can be folded back and fastened with a Velcro strip. Made of breathable, skin-friendly fleece with anti-slip coating.

6370: Size M

6372: Size L

6374: Size XL

6376: Size XXL

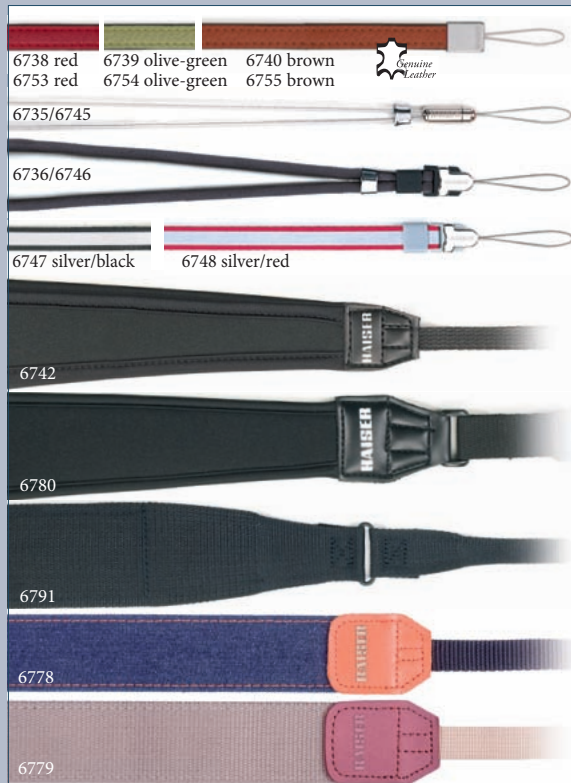

6738 red 6739 olive-green 6740 brown
6753 red 6754 olive-green 6755 brown

6735/6745

6736/6746

6747 silver/black 6748 silver/red

6742

6780

6791

6778

6779

Carrying Straps and Wrist Straps

For compacts with one fastening eye. Also suitable for many mobile phones, MP3 players etc.

6738-40 Wrist strap, genuine leather, length: approx. 22 cm (8.7 in.)

6753-55 Carrying strap, genuine leather, length: approx. 46 cm (18.1 in.)

6735 Wrist strap, silver chain with clear plastic cover, length: approx. 24 cm (9.4 in.)

6745 Neck chain, silver chain with clear plastic cover, length: approx. 46 cm (18.1 in.)

6736 Wrist strap, soft elastic textile fabric, length: approx. 26 cm (10.2 in.)

6746 Carrying strap, soft elastic textile fabric, length: approx. 49 cm (19.3 in.)

6747/48 Reflective carrying strap, with quick release lock, length: approx. 47 cm (18.5 in.)

6742 Neoprene camera strap. High carrying comfort, quick release lock for camera, length: approx. 53 cm (20.9 in.)

Camera Shoulder Straps

For cameras with two fastening eyes. length adjustable.

6780 Neoprene strap. Detachable end sections, can be reconnected to serve as a wrist strap. Length: max. 140 cm (55.1 in.)

6791 Professional camera strap. Heavy-duty strap with non-slip protection. Length: approx. 110 cm (43.3 in.)

6778/79 „Adventure“ camera strap. Heavy-duty strap with non-slip protection. Detachable end sections can be reconnected to serve as a wrist strap. Length: max. 145 cm (57.1 in.)

6778: Denim

6779: Khaki

Light – Compactly Sized

Video needs light – permanently – that is continuous light. Nowadays digital cameras can shoot videos. Small add-on lights, portable and battery-powered, provide adequate illumination in a close-up range when lighting conditions are bad. StarCluster and Co. use up-to-date LED technology, provide energy-saving operation with long-life light sources and can be mounted on all camcorders and movie-making digital camera with standard accessory shoe.

Kaiser StarCluster

This compact soft light works for both, stills and video filming and is perfect for use with D-SLRs and CSCs. It features 96 continuously dimmable white LEDs on a panel of 8.5 x 6 cm (3.3 x 2.4 in.) and provides approx. 600 lux of illumination at one meter (3.3 ft.) and 60° angle of radiation (half-value angle). The colour temperature of 5600 Kelvin relates to daylight. It is powered by five AA batteries fitted in the rear battery compartment or by a Canon LP-E6 battery, that can be placed in an adapter on the battery cover. The LP-E6 is the standard battery for Canon's 5D Mk II, 7D and 60D. There is also a connector for a mains adaptor (optional). The light comes with an diffusion screen and an artificial light filter (3200 Kelvin) which attach to the front of the light by magnetic attachments. The package also contains a swivel joint for mounting to a standard hot shoe.

Specifications:

Operating time with fully charged batteries: up to 2.5 hours
 Colour temperature: 5600 Kelvin
 Dimensions: 127 x 77 x 45 mm (5 x 3 x 1.8 in.)
 Weight: 195 g / 6.9 oz. (without batteries)
 Tripod thread: 1/4"
 Accessories: 3271 mains adaptor



Several lights can be combined side by side or on top of each other using a clever catching system.

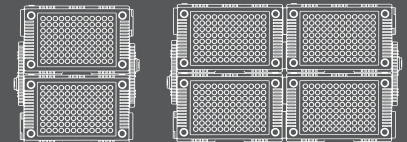
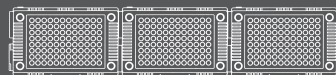

Accessory Bracket



Light metal bracket for mounting two accessories with tripod thread on a tripod, hand grip or swivel joint. Especially suitable for attaching two „StarCluster“ LED lights. Two relocatable 1/4" tripod screws with soft washers. Center placed 1/4" tripod bush.



Length: approx. 15.5 cm (6.1")
 Width: approx. 2.5 cm (1.0")

3273

Small but Mighty

Kaiser SmartCluster „Micro“ **NEW**

Very small and extremely compact LED camera light for photo and video, especially suitable for light-weight CSCs and small camcorders. 24 SMD-LEDs provide approx. 230 lux of illumination at 1 m (3.3 ft.) and 100° angle of radiation (half-value angle) and can be dimmed down continuously to 10 % of maximum value. The light is powered by a NP 60 lithium-ion battery that can be recharged via the included USB cable using a PC, notebook, USB charger or a power bank. There is an indicator lamp for the battery charge condition. To prevent deep discharges and battery defects the light is switched off automatically when the batteries are exhausted. The light comes with a swivel joint with accessory foot and 1/4" tripod thread, a USB charge cable, a diffuser and an artificial light filter with magnetic holders.

Specifications:

Operating time with fully charged batteries: approx. 50 minutes
 Color temperature: approx. 5800 K
 Operating voltage: 3.7 V
 Battery: NP 60, 1200 mAh
 Dimensions (WxHxD): 72 x 51 x 18 mm (2.8 x 2 x 0.7 in.)
 Weight (with battery): approx. 100 g (3.5 oz.)

Kaiser SmartCluster „Midi“ **NEW**

Compact LED camera light for photo and video, suitable for camcorders, DSLRs and CSCs. 80 SMD-LEDs provide approx. 190 lux of illumination at 1 m (3.3 ft.) and 120° angle of radiation (half-value angle) and can be dimmed down continuously to 7 % of maximum value. The light is powered by a NP 120 lithium-ion battery that can be recharged via the included USB cable using a PC, notebook, USB charger or a power bank. There is an indicator lamp for the battery charge condition. To prevent deep discharges and battery defects the light is switched off automatically when the batteries are exhausted. The light comes with a swivel joint with accessory foot and 1/4" tripod thread, a USB charge cable, a diffuser and an artificial light filter.

Specifications:

Operating time with fully charged batteries: approx. 70 minutes
 Color temperature: approx. 5800 K
 Operating voltage: 3.7 V
 Battery: NP 120, 1800 mAh
 Dimensions (WxHxD): 115 x 71 x 21 mm (4.5 x 2.8 x 0.8 in.)
 Weight (with battery): approx. 135 g (4.8 oz.)



Accessory Bracket



For raised mounting of a light, microphone etc. next to the camcorder lens. Folding. With antitwist pin for exact right-angled mounting on camcorder. Widened three-point rest on bottom side. Camera with mounted bracket stands firmly on all flat surfaces. 1/4" tripod thread.



93296

Universal Accessory Bracket

For camcorders and digital SLRs/ CSCs and compacts. Allows for right side or left side mounting of accessories such as lights or microphones. The bracket can be aligned to the camera in different ways.



Angle piece with accessory shoe

1108



Plug-in bracket with detachable anti-twist protection and tripod adapter screw

Variable Light!



3280

Specifications:

Illumination at 1 m (3.3 ft.): max. 960 lux
 Angle of radiation (half-value angle): 50°
 Color rendition index: CRI > 85
 Color temperature: 3200 – 5600 K
 Operating time with 6 NiMH batteries:
 approx. 2.5 hours at full light output
 Dimensions: 152 x 110 x 49 mm (6 x 4.3 x 1.9 in.)
 Weight: approx. 280 g (9.9 oz.) (w/o batteries)

NEW Kaiser StarCluster „144 Vario“

Powerful and dimmable LED camera light with continuously adjustable color temperature. 18 x 8 cm (7.1 x 3.1 in.) panel with 144 High-CRI-LEDs. Color temperature can be adjusted continuously between 3200 Kelvin (warm white/artificial light) and 5600 Kelvin (daylight) via a control dial. Another dial controls the light intensity and shuts the light off. Electronically stabilized light output keeping the illuminance constant when supply voltage goes down. Automatic shutdown when batteries are exhausted to prevent deep discharge and battery defects.

Power supply by 6 AA batteries or rechargeables or Sony L-type battery (NP-F) or mains adapter (accessory, code no. 3281). Additional lights can be connected to all four sides of the light housing. Appropriate connecting adapters are included, also a diffuser screen with magnetic attachment.

1/4" tripod threads on top and bottom sides, in addition continuously adjustable swivel joint with accessory foot for mounting on camera hot shoe.



3283



NEW Kaiser „digiNova focal“

Compact LED camera light with focussing front lens. The light has a selectable automatic brightness adjustment, adapting the intensity of light output to the level of ambient light: Light output is reduced when there is enough ambient light, and increased if ambient light is low. Three color temperature can be selected: 4000, 5500 and 6500 Kelvin. Electronically stabilized light output keeping the illuminance constant when supply voltage goes down. Automatic shutdown when batteries are exhausted to prevent deep discharge and battery defects.
 Mounting foot with fixing nut for attaching the light on the camera hot shoe.

Specifications:

Illumination at 1 m (3.3 ft.): max. 300 lux
 Angle of radiation (half-value angle): 60°
 Operating time with NiMH batteries:
 approx. 80 minutes at full light output
 Power supply: 2 x AA batteries or rechargeables
 Dimensions: 56 x 59 x 89 mm (2.2 x 2.3 x 3.5 in.)
 Weight: approx. 90 g (3.2 oz.) (w/o batteries)

Hand Grip

For lighting units, cameras, etc. With foam shell and grip shape.

Connection thread 1/4" and tripod thread 1/4".

Includes snap-hook with key-ring and fixture for tripod thread.

Height: approx. 120 mm (4.7 in.)



3272

Best Circles



3248

R 48 Ring Light

LED ring light for shadowless illumination in close-up and macro photography. Color temperature of the 48 LEDs is approx. 6000 Kelvin, illumination at 30 cm (1 ft.) approx. 1550 lux and angle of radiation 60°. Mounting on the lens is easy as the unit slides and locks on the suitable adapter ring. Six adapter rings from 49 to 67 mm are included. The light is powered by two AA rechargeable batteries (not included) housed in a separate battery compartment or by a mains adapter 3271 (optional accessory). The 24 LEDs on the left or on the right can be switched on separately.

Minimum working distance: 3 cm (1.2 in.)

Operating time with 2 NiMH rechargeables: approx. 2.5 hours

Colour temperature: approx. 6000 K

Dimensions: Ring light: 11 x 13 x 3 cm (4.3 x 5.1 x 1.2 in.)

Battery compartment: 5 x 9 x 5 cm (2 x 3.5 x 2 in.)

Weight: Ring light: approx. 140 g (4.9 oz.)

Battery compartment: approx. 55 g (1.9 oz.)



3252

NEW R 60 Ring Light

Powerful LED ring light with 60 daylight LEDs (color temperature approx. 5600 K). Illumination approx. 2300 lux at 30 cm (1 ft.) and 52° angle of radiation. Lightweight and compact housing, includes battery compartments and all controls. Power supply by 4 AA batteries or rechargeables. Light can be dimmed continuously down to zero without noteworthy change of color temperature. An external power adapter (not included) can be connected. Mounts to the filter thread of the lens with aid of the appropriate adapter ring. Six adapter rings for 49/52/55/58/62/67 mm filter thread are included.

Minimum working distance: 3 cm (1.2 in.)

Max. operating time with 4 NiMH batteries: approx. 1.5 hours

Dimensions: 15 x 15 x 2.8 cm (5.9 x 5.9 x 1.1 in.)

Weight (w/o batteries): approx. 128 g (4.5 oz.)

Accessory: Universal power adapter with selectable output voltage (code no. 3271)



KR 90 Ring Light

Professional ring light with 30 three-chip high performance LEDs. Illuminance at 30 cm (11.8 in.) approx 1650 lux. Extremely wide angle of radiation of 110° (half-value angle). A rechargeable lithiumion battery and the complete circuitry are integrated in the main body made of highly durable duralumin. Light can be dimmed down. The basic connection thread is 77 mm, several adapter rings from 52 to 72 mm are included. Light can also be mounted on a tripod. No illuminance drop-off due to battery consumption. Automatic shutdown when batteries are exhausted to prevent deep discharge and battery defects. Supply includes quick charger and car charger cable.

Min. working distance: 3 cm (1.2 in.)

Operating time at full illumination: approx. 2 hours

Colour temperature: approx. 5500 K

Battery capacity: 1500 mAh

Tripod thread: 1/4"

Dimensions: ø 142 x 34 mm
(ø 5.6 x 1.3 in.)

Weight: 300 g (10.6 oz.)



3250



Luminaries

The lights of the „PL Vario“ and the „studiolight“ line are absolutely suitable for the small home studio. They are compact, sturdy, easy to use, and the lighting situation is the same for set-up and shooting.

NEW „PL Vario“ LED Soft Lights

These soft lights are designed for studio use mounted on light stands, providing soft and even illumination for photo and video. The light is free from infrared and UV content and completely flicker-free and with no residual ripple due to DC operation. There is almost no heat load. Light intensity and color temperature can be adjusted continuously via control dials on the rear side of the lights. If several lights are used together, they can be controlled by one dial provided that they are connected via a special cable (accessory: light connection cable, 3 m / 9.8 ft., code no. 3469). Generally the lights are powered by the mains adapter supplied with the units, there is also the option for using power packs. All lights can be tilted, the mounting bracket can be detached. Mounting on stands via 16 mm or 28 mm (0.6 in. or 1.1 in.) standard spigot.

connected via a special cable (accessory: light connection cable, 3 m / 9.8 ft., code no. 3469). Generally the lights are powered by the mains adapter supplied with the units, there is also the option for using power packs. All lights can be tilted, the mounting bracket can be detached. Mounting on stands via 16 mm or 28 mm (0.6 in. or 1.1 in.) standard spigot.



3473

3472

3470

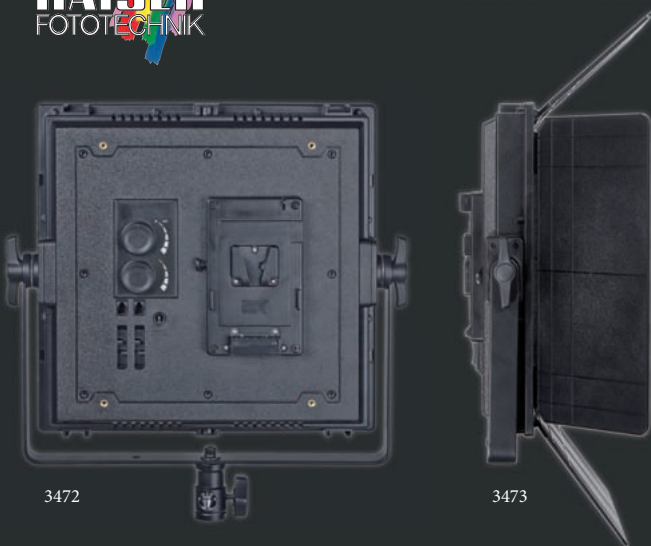

3472

3473

Code no.	3470	3472	3473
Type	PL240 Vario	PL360 Vario	PL840 Vario
LEDs	240	360	840
Color temperature	3200-5600 K	3200-5600 K	3200-5600 K
Color temperature range	CRI > 85	CRI > 85	CRI > 85
Angle of radiation	50°	50°	50°
Max. illuminance (lux)	1 m: 2000 2 m: 500 3 m: 220	1 m: 2570 2 m: 640 3 m: 290	1 m: 7270 2 m: 1820 3 m: 810
Additional features	Front screen	Front screen	4 barn doors
Operating voltage	6-18 V (DC)	10-18 V (DC)	10-18 V (DC)
Dimensions (cm/in.)	35 x 23 x 5.5 13.8 x 9.1 x 2.2	35 x 37.5 x 6.5 13.8 x 14.8 x 2.6	35 x 37.5 x 6.5 13.8 x 14.8 x 2.6
Weight (g/oz.)	1000 / 35.2	1680 / 59.2	1730 / 60.9
Scope of supply	Diffusor screen, connecting adapter for additional light, safety rope		

Light Stands

3195-96: Sturdy matt black light stands with 1/4" / 3/8" reversible thread pin, that can be attached either vertically or horizontally. The center column is air cushioned and thus provides secure use.



3195-96

3195: „Small“ Light Stand.
Four section center column.
Setting height: approx.
75-230 cm (29.5 - 90.6 in.).
Length closed: approx.
70 cm (27.6 in.).
Max. load: 3 kg (6.6 lbs.).
Weight: approx. 1.65 kg
(3.6 lbs.).

3196: „Large“ Light Stand.
Three section center column.
Setting height: approx.
110-290 cm (43.3-114.2 in.).
Length closed: approx.
105 cm (41.3 in.).
Max. load: 10 kg (22 lbs.).
Weight: approx. 2.2 kg
(4.9 lbs.).

3198: Mobile and extremely stable light stand. Folding legs with lockable pivoting rollers. Hole for standard 28 mm (1.1 in.) spigot, concealed standard 16 mm (0.6 in.) spigot. Setting height: approx. 131 to 217 cm (51.6 to 85.4 in.). Load capacity: 25 kg (55 lbs.) on centre. Weight: approx. 7.6 kg (16.7 lbs.).



3198

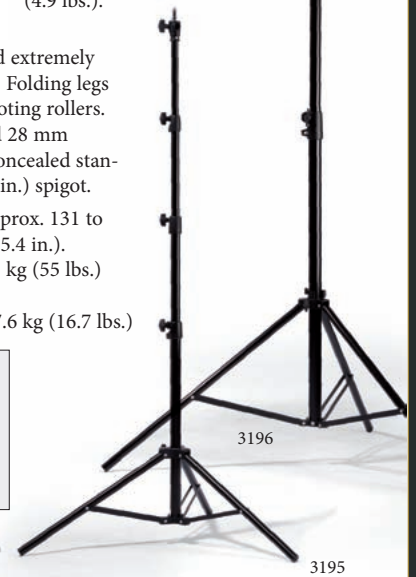

3196

3195



„studiolight 1010“ Halogen Studio Lighting Unit

With 1000 Watt halogen lamp and protective lamp cover made of safety glass. Brightness can be adjusted via step-up/step-down buttons, two-digit display. Light can be switched from set brightness to full brightness and back. Low-noise blower cooling for unlimited operation in every position. Bayonet attachment with quick locking device for accessories (reflectors, soft boxes), swivel joint with locking lever, umbrella mount. Mounts on suitable tripods/stands with 16 mm standard spigot. Includes halogen lamp, exchangeable reflector (180 mm / 7 in. diameter) and protective lamp cover. Code no. 3164



„studiolight 1010 Kit“ Lighting Kit

Comprised of 2 „studiolight 1010“ halogen lighting units (3164), 2 heat resistant soft boxes 60 x 90 cm (23.6 x 35.4 in.) and 2 air-cushioned light stands (setting height 75-230 cm / 29.5-90.6 in.) in a sturdy carrying case. Outside dimensions: 73 x 28 x 44 cm (28.7 x 11 x 17.3 in.). Code no. 3165



Additional accessories for studiolight 1010:



Reflector

Wide beam. With secondary reflector. Removeable heat-resistant fabric diffuser.



Reflector

Narrow beam. Silver coating inside. Matte black coating outside.

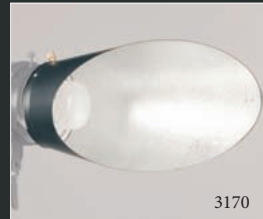

Background Reflector

Can be rotated and locked in any position. Silver coating inside.



Soft Boxes

Heat-resistant, with ventilation flaps. 60 x 60 cm / 23.5 x 23.5 in. (3177) and 100 x 100 cm / 39.5 x 39.5 in. (3178).



NEW „studiolight E70“ Lighting Kit

Comprised of two soft boxes 50 x 50 cm (20 x 20 in.) with incorporated E27 lamp socket and swivel joint, two daylight photofloods (energy saving lamps 70 W, 5400 K), two light stands and carrying bag. Soft boxes with umbrella mechanism for fast and simple setup. Detachable front diffuser. Tilttable lamp holder with 2.8 m (9.2 ft.) mains lead and cable switch. Can be equipped with compact fluorescents up to 200 watt and up to 31 cm (12.2 in.) overall length. Not suitable for incandescents. Light stands have setting height of 70 - 190 cm (27.6 - 74.8 in.), 16 mm standard spigot and 1/4" tripod thread.

Padded carrying bag with handle and detachable shoulder strap.



Photofloods

For 3167. Energy saving lamps 5400 K, E27 with 70 W (3112) or 135 W (3113).

NEW



Desktop Studios



5906

Desktop studios can be set up on your desk, on your dining or living room table or wherever you like to take your pictures. They are most suitable for small object photography resulting in pictures you may need for your website, for internet auctions, for online shops or for documentation of valuables or collectables.

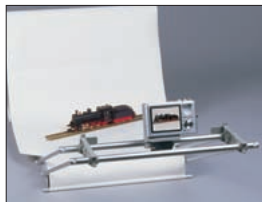

NEW Studio-out-of-the-Box 2

Compact foldable studio for digital photography. Comprises table, background support, background material white, black and blue, smartphone mount and trapeze stand for cameras up to 500 g (1.1 lbs.). On the trapeze stand the camera can be positioned in many different positions and at different heights and distances from the object. The camera platform is pivotable and relocatable and

can be locked in a vertical shooting position. Table can be extended up to 30 cm (11.8 in.), background can be positioned at different heights. Background roll included, approx. 40 cm (15.7 in.) wide and 130 cm (4.25 ft.) long. To support wider backgrounds a clip-on rail is included. Dimensions (folded): 59 x 6 x 33 cm (23.2 x 2.4 x 13 in.). Supplied with carrying box. A suitable lighting set (2 x 8 W, 4000 K) is available as an accessory (5914).



5883

„Open Tube 1“ Shooting Table

The evenly curved background ("open tube" outline) improves the distribution of light on the subject. This shooting table is assembled by the user. The background made of flexible plastic material is inserted into the assembled table and fixed by Velcro fittings. Dimensions 77 x 60 x 85 cm (30.3 x 23.6 x 33.5 in.). Side frames of the table provide attachment points for one or more lighting modules in vertical or horizontal position. Suitable lighting module, high frequency operated: 5884 (36 W, 5400 K).



5884



5891

„Dome-Studio“ Light Tent

White translucent surfaces provide even and soft illumination. Umbrella-type construction makes set-up and fold-down easy. Equipped with „snow flaps“ for outdoor use to prevent it from blowing away in strong winds. Supplied with reversible textile background (blue/grey) and protective cover with carrying straps.

5891: Floor size: 62 x 62 cm (24.5 x 24.5 in.), height: 51 cm (20 in.)
5892: Floor size: 75 x 75 cm (29.5 x 29.5 in.), height: 65 cm (25.5 in.)



5846

NEW „easy-fit“ Shooting Table

5845: Compact shooting table, comprised of a foldable tubular steel frame and a white translucent plastic sheet with preformed front edge. Easy set-up and take-down without need of tools, space-saving storage. Base frame with nonskid feet and holding provisions for accessories on both sides.

Level work space on table: approx. 59 x 37 cm (23.2 x 14.6 in.).

Height of backdrop: approx. 35 cm (13.8 in.).

19 cm (7.5 in.) free space underneath the table for a transmitted light source (light box).

Total dimensions: (WxHxD): 70 x 54 x 68 cm (27.6 x 21.3 x 26.8 in.).

Weight: approx. 3.4 kg (7½ lbs.).

NEW „easy-fit“ Shooting Kit

5846: Consists of „easy-fit“ shooting table (5845) and desktop lighting kit 2 (5862).

Table-Top-Studio digital



5994/96

Complete desktop studio, consisting of Small Product Table 5931 and lighting unit. Product table with white translucent concave shaped acrylic background. Required desk space approx. 50 x 50 cm (20 x 20 in.). Lighting unit consists of two small soft lights for even and smooth illumination and holding rods with multiple orientation possibilities, screw-on clamps for attachment.

Table-Top-Studio digital SN-HF (5993) with RB 218N HF daylight lighting system (5464) with two compact fluorescents, 18 W each, 5400 K, CRI = 90-100. Table-Top-Studio digital SN-HF plus (5994) with additional camera clamp holder comprising a swan-neck arm, a ball head and a desk clamp.

Also available with RB 5020 DS LED daylight lighting system (5465) with 192 white high-CRI LEDs on each side: Table-Top-Studio digital LED (5995) and Table-Top-Studio digital LED plus (5996). Lights can be dimmed individually or synchronized, 5600 K, CRI > 85, angle of radiation: 60°.



5893

„Cube-Studio“ Light Tent

This cube-shaped light tent allows for even and soft illumination. Detachable front cover with slot for camera lens. Easy to set up, folds up automatically. Highly flexible frame, can be folded down to compact size. Includes reversible textile backdrops white/grey and black/blue and carrying pouch with wrist strap.

5893: 50 x 50 x 50 cm (19.5 x 19.5 x 19.5 in.)

5894: 90 x 90 x 90 cm (35.5 x 35.5 x 35.5 in.)

Desktop Lighting

5861: Desktop Lighting Kit 1: reflector light, consisting of lamp holder 5860, reflector (27 cm / 10.6 in. diameter) with removable diffusing cover and light stand 5859. Incl. energy saving lamp 3110.

5862: Desktop Lighting Kit 2, comprises two sets 5861.

5860: Lamp Holder with E27 ceramic socket, for photofloods up to 250 watts. With ON/OFF switch and swivel joint with umbrella mount. Mounts on suitable tripods/stands with 16 mm standard spigot. Mains lead approx. 3.80 m (12.5 ft). 1 piece. Without lamp and reflector.

5858: Desktop Light Stand, height 22-38 cm (8.7-15 in.)

5859: Desktop Light Stand, height 35-70 cm (13.8-27.6 in.)

3110: Energy Saving Lamp, 25 W, 6400 K, E27



5860

Desktop Shooting Kit

Comprehensive kit for object photography. Consists of a „Cube-Studio“ light tent for even and soft light distribution and two reflector lights on desktop stands (Desktop Lighting Kit 2, code no. 5862).

5863: with Cube-Studio 5893 (50 x 50 x 50 cm)

5864: with Cube-Studio 5894 (90 x 90 x 90 cm)



5863

Mini Magic Arm

To mount and individually align cameras, lights and accessories. 1/4" mounting thread. Central locking knob. Comes with multiple mounting adapters. Maximum load in horizontal position: 1 kg (2.2 lbs.).

5055: Magic Arm mini 1.

Total length approx. 18 cm (7.1 in.)

5056: Magic Arm mini 2.

Total length approx. 29 cm (11.4 in.)



Universal Clamp

Attaches on tubes and boards. Span width max. 42 mm (1.7 in.). Two threaded holes 1/4" and 3/8". Includes spigot with 1/4" and 3/8" threaded pins.



5023

For Everything That Won't Fit Your Scanner!

Just in case something would not fit on your scanner – too big, too bulky, too wide etc. – here is where it belongs. Combine these stands with your camera and enjoy a perfect image capturing tool for all „awkward“ items that need to be photographed from above: the vintage LP cover, grandfather's precious pocket watch or just a section out of a large-sized road map. Suitable lights – now also available with LEDs – for even illumination, can easily be added.

RS 2 XA Camera Stand

Non-reflective matt grey base board with printed fine grid and cm/inch scale. Matt-black anodised aluminium-section tube column with cm/inch scale. Hand-cranked height adjustment. Horizontally adjustable camera arm. 1/4" mounting thread. Base board (WxHxD): approx. 40 x 2.5 x 50 cm (15.7 x 1 x 19.7 in.). Column height: approx. 76 cm (30 in.). Maximum load: 1.5 kg (3.3 lbs.). Code no. 5411



5411 with 5465



5360

„reprokid“ Copy Stand

Super-compact copy stand for small, lightweight cameras. Non-reflective, matt-black base board. Column with cm/inch scale. Height-adjustable camera arm. 1/4" mounting thread. Base board (WxHxD): 32 x 1.9 x 38 cm (12.6 x 0.7 x 15 in.). Column height: 59 cm (23.2 in.). Max. load: 1 kg (2.2 lbs.). Includes lighting unit with two E27 screw-in mounts for lamps up to 250 watt (supplied without lamps). Code no. 5360

Suitable lighting units for RS 2 XA copy stand:

RB 5020 DS LED Lighting Unit



With two small light banks, each with 192 white high-CRI LEDs, 5600 K, angle of radiation: 60°. Lights can be dimmed individually or synchronized. Lights are tiltable and adjustable in height. Angle of vertical arms adjustable by lock joint. Mounted with strong die-cast clamp bases. Code no. 5465

RB 218N HF Lighting Unit

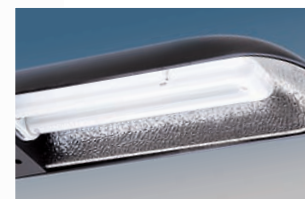

With two small light banks with interior reflector and 18 W, 5400 K daylight fluorescent lamp. High frequency operating system. Lights are tiltable and adjustable in height. Angle of vertical arms adjustable by lock joint. Mounted with strong die-cast clamp bases. Code no. 5464

RB 2 Lighting Unit



With four tiltable and adjustable reflectors on mounting arms which are in turn tiltable and adjustable in height. Lights can be switched on separately. Suitable lamps: 4 x 150 W max., E27. Supplied without lamps. Code no. 5450

Pixel-Perfect Cut?

This is not required. But it would be nice to have all the things “produced” on your printer with a neat and precise cut. This makes a trimmer a PC peripheral – it is very useful anyway.

„easy cut“ Safety Trimmer

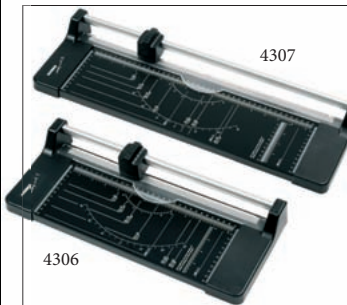

Easy and safe cutting with ground circular blade. Automatic paper clamping at cutting position. Sturdy metal base board with scales, format and angle markings.

- 4306: easy cut 1
Cutting length: 32 cm (12.6 in.)
Cutting thickness: 1 mm (0.04 in.)
- 4307: easy cut 2
Cutting length: 45 cm (17.7 in.)
Cutting thickness: 0.8 mm (0.03 in.)

„hobby cut“ Safety Trimmer



Self-sharpening circular blade in closed plastic housing. Automatic paper clamping at cutting position. Transparent paper-holding strip. Two angle stops with cm and inch scales. Sturdy metal base board with printed fine grid, scales, format and angle markings.

- 4313: hobby cut 3
Cutting length: 33 cm (13.0 in.)
Cutting thickness: 1 mm (0.04 in.)
- 4314: hobby cut 4
Cutting length: 46 cm (18.1 in.)
Cutting thickness: 1 mm (0.04 in.)

NEW „multi cut“ Guillotine-type Trimmer



Safety trimmer with honed top and bottom blades. Manual pressing rail. Angle guide on both sides for right-angled cutting, with cm and inch scales. Detachable magnetic back stop. Trimmer base with cm and inch scales and format and angle markings.

- 4303: multi cut 3
Cutting length: approx. 34 cm (13.4 in.)
Cutting thickness: 1.5 mm (0.06 in.)
Base dimensions: 45 x 28.5 cm (17.7x11.2 in.)
- 4305: multi cut 4
Cutting length: approx. 46 cm (18.1 in.)
Cutting thickness: 1.5 mm (0.06 in.)
Base dimensions: 57.5 x 28.5 cm (22.6x11.2 in.)

Pocket Magnifier

Flat magnifier with LED light. The LED lights up when loupe slides out.



- Magnification: 3x
- Lens size: 45 x 38 mm (1.8 x 1.5 in.)
- Incl. batteries.

Hand-Held Magnifier

Stylish magnifier with LED illumination. Ergonomically designed handle. Lens edge matt-finished and rounded off. Batteries included.



- 2368: Lens diameter: 65 mm (2.6 in.), magnification: 2.4x
- 2369: Lens diameter: 80 mm (3.2 in.), magnification: 2.2x

NEW Pocket Microscope

30 x magnification. With focussing mechanism and rotatable illumination for the viewing field. Dimensions (HxWxD): approx. 140 x 45 x 20 mm (5.5 x 1.8 x 0.9 in.)



Worth Watching!

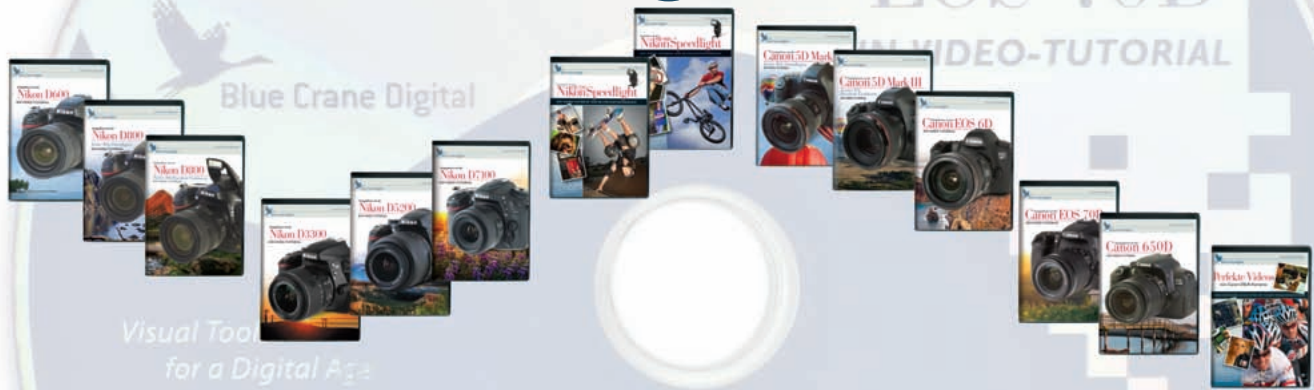

Visual Tool
for a Digital Age

Today's digital cameras and flashguns offer an almost endless number of features and settings. Manuals covering every detail require several hundred pages.

To get the most out of your digital SLR or flashgun quickly and easily you should try these video tutorials from Blue Crane Digital. All you need now is a DVD player and about two hours of your time. Then you will learn how to create the images you want. You can closely follow settings and procedures, basic knowledge will be explained and sample images will show the results. All topics are arranged in chapters, so you can move at your own pace and return later to individual subjects.

These German language DVDs are produced specifically for the European market and are distributed exclusively by Kaiser Fototechnik.

Available Titles:

- Canon EOS 5D Mk III, Grundlagen (6434)
- Canon EOS 5D Mk III, Erw. Funktionen (6435)
- Canon EOS 6D (6426)
- Canon EOS 70D (6423)
- Canon EOS 650D/700D (6430)
- Perfekte Videos mit Canon DSLR-Kameras (6449)
- Nikon D600/D610 (6429)
- Nikon D800, Grundlagen (6432)
- Nikon D800, Erw. Funktionen (6433)
- Nikon D3200/D3300 (6422)
- Nikon D5200/D5300 (6428)
- Nikon D7100 (6425)
- Nikon Speedlight SB-700 (6457)
- Nikon Speedlight SB-910 (6456)

Please note: Tutorials are German language only.

The Catalogue



More information on the comprehensive Kaiser range of products can be found in the Kaiser general catalogue. Available from your dealer or through Kaiser distributor in your country.

Lighting equipment and lamps as described in this brochure are marketed for the primary purpose of illumination for image capture and not for household lighting.

USA

HP Marketing Corp.
16 Chapin Road Unit 908
P.O. Box 715
Pine Brook, NJ 07058
Tel +1 973 8089010
Fax +1 973 8089004
www.hpmarketingcorp.com
info@hpmarketingcorp.com

United Kingdom

Fotospeed Distribution
Jay House Ltd.
6B, Park Lane Industrial Estate
Park Lane, Corsham
Wilts, SN13 9LG
Tel +44 1249 714 555
Fax +44 1249 714 999
info@fotospeed.com
www.fotospeed.com

Canada

Nadel Enterprises Inc.
425 Attwell Drive
Rexdale, Ontario
M9W 5C4
Tel +1 416 7452622
Fax +1 416 7422616
www.nadel.ca
info@nadel.ca

Australia

Alderson Camera Stores Pty. Ltd.
364 Kent St
P.O. Box Q 97, QVB Postshop
2000 Sydney
Tel +61 2 9299 6745
Fax +61 2 9299 1658
showroom@fotoriesel.com.au
www.fotoriesel.com.au

New Zealand

Photo Warehouse Ltd.
175 GT North Rd.
Ponsonby-Auckland
Tel +64 9 3032148
Fax +64 9 3099721
www.photowarehouse.co.nz
enquiries@photowarehouse.co.nz

175 YEARS
PHOTOGRAPHY
IMAGING UNLIMITED

Kaiser Fototechnik GmbH & Co. KG

Im Krötenteich 2 · 74722 Buchen · Germany

Tel.: +49 6281 4070

Fax: +49 6281 40755

www.kaiser-fototechnik.de

info@kaiser-fototechnik.de

